

HARBOUR ISLES

Being a replat of Lots 1 through 5, Block 54, Village of North Palm Beach, Plat No. 6, as recorded in Plat Book 26 pages 10 through 12, and being a portion of Section 8, Township 42 South, Range 43 East, Village of North Palm Beach, Palm Beach County, Florida. Sheet 11 of 11 August 1999

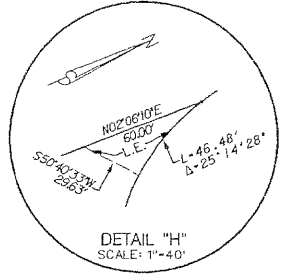
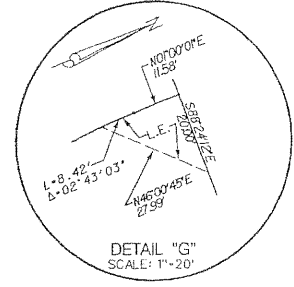
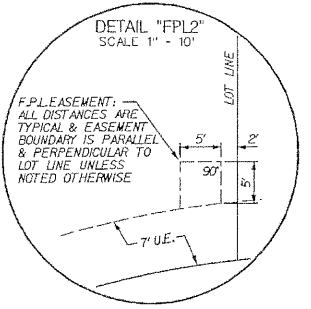

LIDBERG LAND SURVEYING, INC.

LB4431 675 West Indiantown Road, Suite 200, Jupiter, Florida 33458 TEL: 301-740-8454

CAD: K:\USTATION \ SECTION \ 08-42-43 \ 96-594 \ SHEET1.DGN			
REF: K:\USTATION \ SECTION \ 08-42-43 \ 96-594 \ 96-594.DGN			
FLD.	FB.	PG.	JOB 96-594
OFF. R.W.			DATE 10/14/96
CKD. D.C.L.	SHEET 11	OF 11	DWG. 096-594P